



**Aladin ONE  
(Matrix)  
User Manual**



**deep down you want the best**

[scubapro.com](http://scubapro.com)

# ALADIN ONE DIVING COMPUTER - DESIGNED BY DIVING ENGINEERS

Welcome to SCUBAPRO dive computers and thank you for purchasing the Aladin One. You are now the owner of an extraordinary partner for your dives. This manual provides you with easy access to SCUBAPRO state-of-the-art technology and key Aladin One features and functions. Should you wish to know more about SCUBAPRO diving equipment, please visit our website at [www.scubapro.com](http://www.scubapro.com).



## IMPORTANT

Please carefully read and understand the **Read First** booklet that is included in the package before using your SCUBAPRO Aladin One.

## WARNING

- The Aladin One has a depth rating of 120m/394ft.
- If 120m/394ft is exceeded, “---“ will appear in the depth field and the decompression algorithm will not calculate correctly.
- Diving at oxygen partial pressures higher than 1.6bar (corresponding to a depth of 67m/220ft when breathing compressed air) is extremely dangerous and could lead to serious injury or death.

## WARNING

- The Aladin One is delivered in deep sleep mode with the display off. You must activate the Aladin One by pressing and holding the left or right button before the first dive. The Aladin One will not start the dive mode or may show the wrong depth value if activation is not done before immersion.



The Aladin One dive instrument is compliant with the European Union directive 2014/30/EU.

**Standard EN 13319: 2000**

The Aladin One dive instrument is also compliant with the European standard EN 13319: 2000 (EN 13319: 2000 – Depth gauges and combined depth and time measuring devices – Functional and safety requirements, tests methods).

## TABLE OF CONTENTS

<b>1. INTRODUCTION</b>	<b>5</b>
1.1 Safety considerations	5
1.2 Quick reference of the display layout	5
<b>2. SYSTEM AND OPERATION</b>	<b>6</b>
2.1 System description	6
2.2 Operation	6
2.2.1 Push buttons	7
2.2.2 Water contacts	7
2.2.3 Switching on the display	7
2.2.4 How to navigate the Aladin One at the surface	8
2.2.5 Checking the desaturation time	8
2.2.6 Checking the surface interval	8
2.2.7 Checking the battery condition	9
2.2.8 Active backlight	10
2.2.9 Switching off the display	10
2.2.10 Alarm clock	10
2.3 SOS mode	10
<b>3. DIVING WITH YOUR ALADIN ONE</b>	<b>11</b>
3.1 Terminology/Symbols	11
3.1.1 General terminology/Display during no-stop phase	11
3.1.2 Display during decompression phase	11
3.1.3 Nitrox information (O <sub>2</sub> information)	12
3.2 Attention messages and alarms	12
3.2.1 Attention messages	12
3.2.2 Alarms	13
3.3 Preparation for the dive	13
3.3.1 Function check	13
3.3.2 Setting the gas mixture and ppO <sub>2</sub> max	13
3.4 Functions during the dive	14
3.4.1 Alternate displays	14
3.4.2 Dive time	14
3.4.3 Current depth/O <sub>2</sub> % mix	14
3.4.4 Max depth/Temperature	14
3.4.5 Set max depth reached	15
3.4.6 Ascent rate	15
3.4.7 Partial pressure of oxygen (ppO <sub>2</sub> max)/ Maximum operating depth (MOD)	16
3.4.8 Oxygen toxicity (CNS O <sub>2</sub> %)	16
3.4.9 Decompression information	17
3.4.10 Decompression values	17
3.4.11 Total ascent time	18
3.4.12 Safety stop timer	18
3.5 Functions after the dive	18
3.5.1 End of a dive	18
3.5.2 Desaturation time, No-fly time and No-dive warning	19
3.6 Diving in mountain lakes	20
3.6.1 Altitude classes	20
3.6.2 Prohibited altitude	20
3.6.3 Decompression dives in mountain lakes	20

<b>4.</b>	<b>FUNCTIONS ON THE SURFACE .....</b>	<b>21</b>
4.1	Dive planner .....	21
4.1.1	Planning a no-stop dive .....	21
4.1.2	Planning a decompression dive .....	22
4.1.3	Leaving the dive planner .....	22
4.2	Logbook .....	23
4.2.1	Survey .....	23
4.2.2	Operation .....	23
4.2.2.1	Page 1 .....	24
4.2.2.2	Page 2 .....	24
4.2.2.3	Page 3 .....	24
4.2.2.4	Statistical information (HISTORY) .....	24
<b>5.</b>	<b>SETTINGS .....</b>	<b>25</b>
5.1	Dive menu .....	25
5.1.1	Gas menu .....	26
5.1.2	Scuba menu .....	26
5.1.3	User menu .....	28
5.2	Watch menu .....	29
5.2.1	Setting the alarm clock time .....	29
5.2.2	Setting the UTC offset (coordinated universal time) .....	30
5.2.3	Adjusting the time of day .....	30
5.2.4	Selecting 24-hour or AM/PM setting .....	30
5.2.5	Adjusting the date .....	31
5.2.6	Switching the sound on and off .....	31
5.2.7	Check the battery status .....	32
<b>6.</b>	<b>INTERFACING WITH WINDOWS/MAC AND APPS .....</b>	<b>32</b>
6.1	Introduction to SCUBAPRO LogTRAK .....	32
6.2	Changing warnings/settings of the Aladin One and reading computer information .....	33
<b>7.</b>	<b>TAKING CARE OF YOUR ALADIN One .....</b>	<b>34</b>
7.1	Technical information .....	34
7.2	Maintenance .....	34
7.2.1	Replacing the battery .....	35
<b>8.</b>	<b>APPENDIX .....</b>	<b>36</b>
8.1	Warranty .....	36
8.2	Glossary .....	37
8.3	Index .....	38

## 1. INTRODUCTION

Your Aladin One User Manual is divided into the following main chapters.

1. Introduction
2. System and operation
3. Diving with your Aladin One
4. Functions on the surface
5. Settings
6. Interfacing with Windows/Mac and Apps
7. Taking care of your Aladin One
8. Appendix (warranty, glossary, index).

### 1.1 Safety considerations

Dive computers provide divers with data; however, they do not provide the knowledge of how this data should be understood and applied. Dive computers cannot replace common sense! You must therefore carefully read and understand this entire manual before using your Aladin One.

### 1.2 Quick reference of the display layout

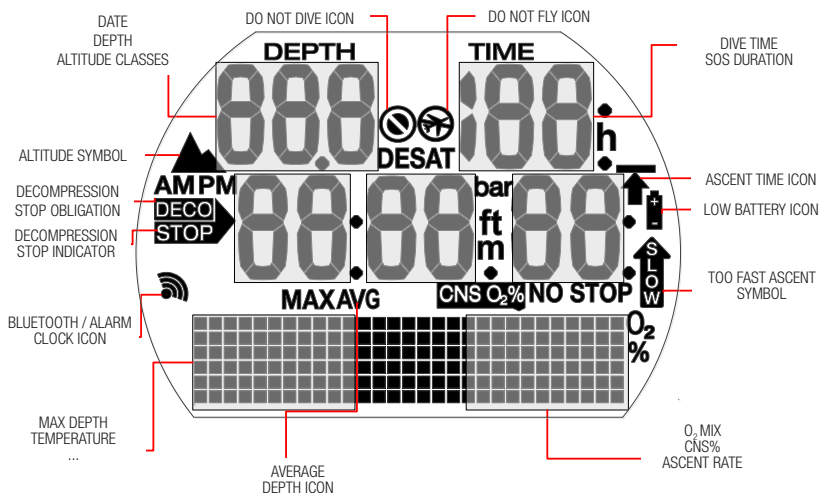

## 2. SYSTEM AND OPERATION

### 2.1 System description

The Aladin One displays all important dive and decompression data and has a memory which stores the full dive data. This data can be transmitted with a Bluetooth interface and LogTRAK software to Windows or Mac personal computers, Android devices or Apple devices.

LogTRAK software is available at the SCUBAPRO website as well as the Android Play Store and iPhone App Store.

### 2.2 Operation

Operating schematic

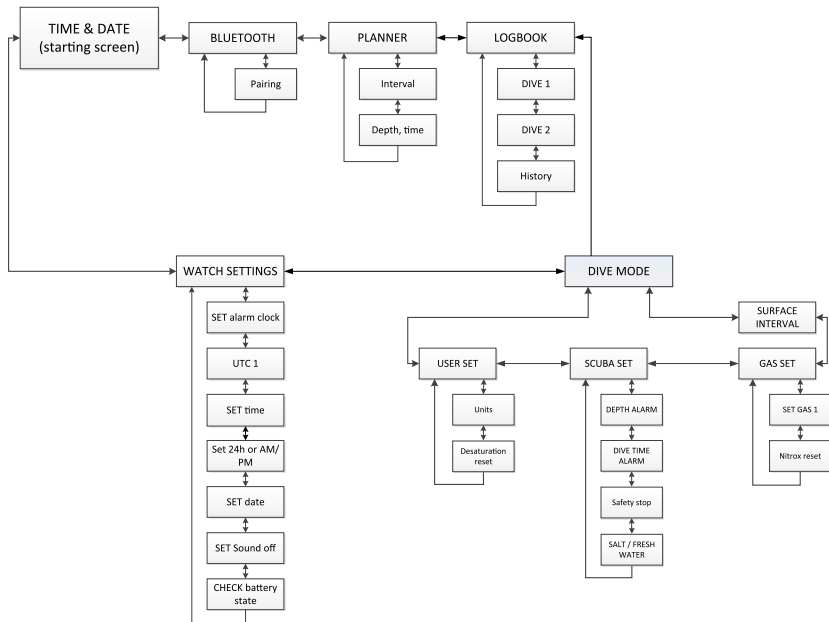

## 2.2.1 Push buttons

The Aladin One's features are accessed and controlled with 2 push buttons. Operation of these push buttons is divided into 2 methods: "press" and "press-and-hold" (for 1 second) – also referred to as a "long" press on the menu diagrams. Each method allows you to access different computer functions.



### At the surface:

**PRESS-AND-HOLD LEFT OR RIGHT BUTTON:**

- Switches on the Aladin One (time of day display).

**PRESS-AND-HOLD RIGHT BUTTON:**

- Functions like the ENTER/RETURN key on a keyboard.
- Provides access to the displayed sub menu.
- Opens the displayed setting.
- Confirms the displayed value or setting selection.

**PRESS LEFT OR RIGHT BUTTON:**

- Allows scrolling through menus.
- Once entered into a sub menu or series of settings:
  - Increases (press right button) or decreases (press left button) the indicated value or setting.

**PRESS-AND-HOLD LEFT BUTTON:**

- Activates the backlight in time of day display.
- Escape the current function or menu to last level or setting.

**PRESS-AND-HOLD BOTH BUTTONS:**

- Exits the current function or menu and switches to the time of day display.
- From the time of day display, switches off the Aladin One.

## SCUBA mode:

**PRESS RIGHT BUTTON:**

- Accesses alternate displays.

**PRESS-AND-HOLD LEFT BUTTON:**

- Operates the backlight.

**PRESS LEFT BUTTON:**

- Activates the safety stop timer (in depths < 5m/15ft).

## 2.2.2 Water contacts

Upon submerging, the water contacts activate the Aladin One automatically.

## 2.2.3 Switching on the display

All segments on:

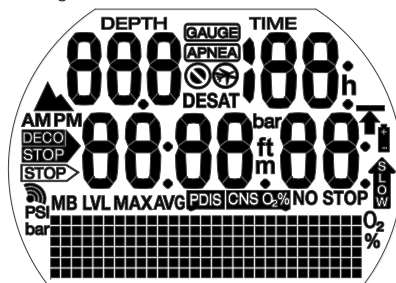

Start up display with time:

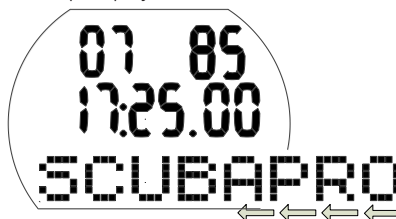

**NOTE:** On the lower matrix row on the display, longer words are scrolled. In this manual, such scrolling is indicated by left-pointing arrows running along the bottom of the display.

Time of day display:



The Aladin One switches on:

- Automatically, upon submerging in water or when triggered by a change in atmospheric pressure.
- Manually, by pushing and holding either the left or right button.

If switched on with the left button, all display segments appear for 5 seconds. Afterwards, the display shows the time of day, the date and a scrolling SCUBAPRO which is quickly replaced by the day of the week. This is referred to as the “time of day” display.

In the time of day display, if there is remaining saturation from the last dive or from a change of altitude, the Aladin One may indicate the “Do not fly” icon, “Do not dive” icon or “Altitude” icon or a combination of the icons depending on the situation.

**NOTE:** Most navigation descriptions in this manual start from the time of day display. At the surface, the Aladin One returns automatically to this display.

**NOTE:** When the Aladin One is in a state of rest, no information is displayed but the atmospheric pressure continues to be monitored. If a change in altitude classes is detected, the Aladin One automatically switches on for 3 minutes.

**NOTE:** Without active use the Aladin One's display automatically reverts to the time of day display, and after 3 minutes the computer switches off.

### 2.2.4 How to navigate the Aladin One at the surface

Starting from the time of day display you can enter into different menus.

### 2.2.5 Checking the desaturation time

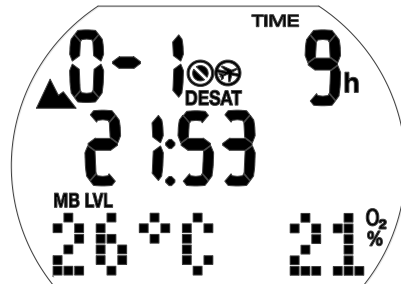

From the time of day display you can check the desaturation time\* with a press-and-hold of the right button. Desaturation time is determined either by oxygen toxicity, nitrogen saturation or the regression of microbubbles, depending on which requires the longer time.

\*Desat time is displayed only if there is remaining saturation due to the last dive or a change of altitude.

### WARNING

For calculations of desaturation and no-fly time it is assumed that you are breathing air while on the surface.

### 2.2.6 Checking the surface interval



From the time of day display you can check the surface interval with a press-and-hold of the right button (taking you directly to the dive menu) and then another press-and-hold (taking you to surface interval).

Surface interval is the elapsed time since the end of your last dive; it is displayed as long as there is remaining saturation.



## 2.2.7 Checking the battery condition



From the time of day display you can check the battery condition by pressing the left or right button to scroll to the watch menu. With a press-and-hold of the right button you enter watch settings, then press the right button 6x to scroll to the battery status screen.

The battery status screen shows how much energy is left in the CR2450 battery. A fresh battery is indicated by 6 zeros.

While the Aladin One periodically monitors battery status, you can manually trigger a status check with a press-and-hold of the right button while in this screen.

The Aladin One's intelligent battery algorithm will limit some functions as you near the end of the battery's life. See the table below for battery status and corresponding function limitations.

**NOTE:** Battery capacity and voltage at the end of a battery's lifetime may vary between battery manufacturers. Generally, operation at low temperatures decreases battery capacity. Therefore, when the battery indicator drops below 4 zeros, change the battery to a fresh one before making any new dives.



### **⚠ WARNING**

When the battery is critically low, the watch settings are disabled (the watch set menu is "OFF").

Indicator in battery status display	At other displays	Battery status	Function limitations
000000		Fresh battery	none
_00000		Battery ok for diving	none
__0000		Battery ok for diving	none
___000	Battery symbol	Weak battery, change to fresh	<b>Backlight not operating</b>
____00	Blinking battery symbol, no dive symbol	Completely used battery, change to fresh	<b>Buzzer and backlight not operating, diving not recommended</b>
_____0	Blinking battery symbol, no dive symbol	Completely used battery, change to fresh, Aladin One may make a reset any time and remain off	<b><u>Diving mode not allowed, only watch is active. Settings cannot be changed (OFF)</u></b>

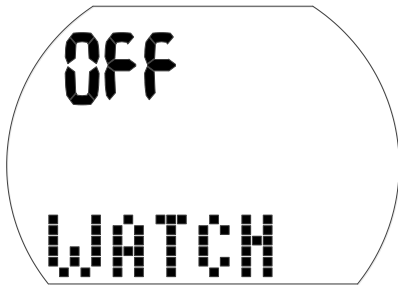

### ⚠ WARNING

- If the battery status graph shows only 2 zeros, the battery symbol will blink, both on the surface and in dive mode, to alert you of a dangerous situation. At this point the battery may not have enough energy to finish a dive. In such a case, audible alarms and attention messages are disabled, the backlight is deactivated, and you run the risk of a computer malfunction. **Do not let the battery reach this condition!**
- Always replace the battery when the steady battery symbol appears (3 zeros).

👉 NOTE: Logbook information is not lost even when the battery is removed for an extended period of time.

### 2.2.8 Active backlight

The display of the Aladin One can be illuminated both on the surface and under water. The backlight can be activated with a press-and-hold of the left button.

The light will turn off automatically after 6 seconds.

👉 NOTE: Repeated activation of the backlight will reduce battery life.

The Aladin One monitors the battery level throughout every dive, and if the available energy drops below the warning threshold, the Aladin One will automatically disable the backlight to prevent a computer shut-down.

### 2.2.9 Switching off the display

From the time of day display you can switch off the Aladin One by pressing and holding both buttons simultaneously. On the surface the Aladin One switches off automatically after 3 minutes of non-use.

### 2.2.10 Alarm clock

The alarm clock tone works only at the surface.

If the alarm clock is “on” the time of day display shows the alarm clock/transmit symbol.



When the alarm is triggered, the alarm clock/transmit symbol flashes and special attention beeps sound for 30 seconds or until you press a button.

## 2.3 SOS mode



SOS mode (lock duration 24 hours) and surface interval from the dive

If you remain above a depth of 0.8m/3ft for more than 3 minutes without observing a prescribed decompression stop, the Aladin One will automatically switch into SOS mode after the dive and remain there for 24 hours. The dive will be entered in the logbook with “SOS.”

Push the right button to see the “SOS” symbol (the SOS mode will be unlocked after 24 hours).

While in SOS mode, the Aladin One cannot be used for diving.

**NOTE:** Diving within 48 hours after exiting SOS mode will result in shorter no-stop times or longer decompression stops.

### ⚠ WARNING

- Serious injury or death may result if you do not seek immediate treatment should any signs or symptoms of decompression sickness occur after a dive.
- DO NOT dive to treat symptoms of decompression sickness!
- Diving in SOS mode is extremely dangerous and you must assume full responsibility for such behavior. SCUBAPRO will assume no liability.

**NOTE:** A diving accident can be analyzed at any time in the logbook and downloaded to a PC by means of the Bluetooth interface and LogTRAK software.

## 3. DIVING WITH YOUR ALADIN ONE

### 3.1 Terminology/Symbols

The information on the display of the Aladin One varies depending on the kind of dive and the dive phase.

#### 3.1.1 General terminology/Display during no-stop phase

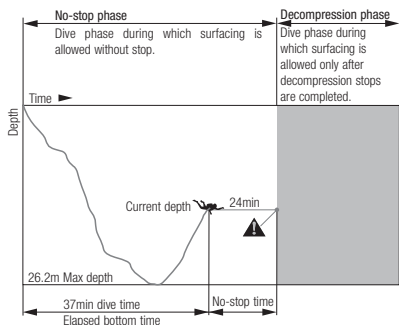
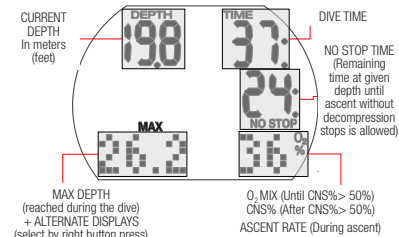

#### 3.1.2 Display during decompression phase

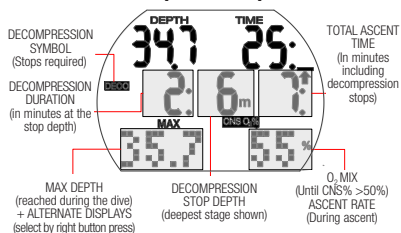

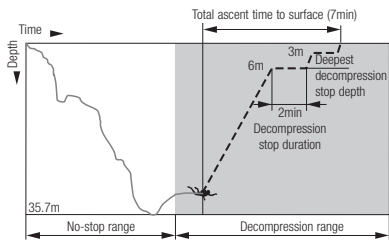

### 3.1.3 Nitrox information (O<sub>2</sub> information)

For dives with compressed air in normal recreational diving, nitrogen is the decisive gas for decompression calculations. When diving with nitrox, the risk of oxygen toxicity rises with the increase of the fraction of oxygen and the increase of depth; this can limit dive time and max depth. The Aladin One includes this in its calculations and displays the necessary information:

**O<sub>2</sub>% mix Fraction of oxygen:** The fraction of oxygen in the nitrox mixture can be set between 21% (normal compressed air) and 50% in 1% increments. Your selected mix will be the basis for all calculations.

**ppO<sub>2</sub> max Maximum allowed partial pressure of oxygen:** The higher the fraction of oxygen in the mixture, the shallower the dive depth at which this value of the partial pressure of oxygen is reached. The depth at which the ppO<sub>2</sub> max is reached is called Maximum Operating Depth (MOD).

When you enter the settings for the gas mixture, the Aladin One will display the ppO<sub>2</sub> maximum limit setting and the corresponding MOD. The Aladin One warns you audibly and visually once the depth, at which the ppO<sub>2</sub> reaches the maximum allowed value, is reached.

**NOTE:** The default setting of ppO<sub>2</sub> max is 1.4bar. The value of ppO<sub>2</sub> max can be set between 1.0bar and 1.6bar at the gas settings. The CNS O<sub>2</sub>% value/ alarm is not influenced by the selected ppO<sub>2</sub> max setting.

**CNS O<sub>2</sub>% Oxygen toxicity:** With the increased percentage of oxygen, the oxygen in the tissues, especially in the central nervous system (CNS), becomes

important. If the partial pressure of oxygen rises above 0.5bar, the CNS O<sub>2</sub> value increases; if the partial pressure of oxygen is below 0.5bar, the CNS O<sub>2</sub> value decreases. The closer the CNS O<sub>2</sub> value is to 100%, the closer the limit where symptoms of oxygen toxicity can occur.

During the dive, the depth at which ppO<sub>2</sub> reaches 0.5bar with various commonly-used mixes is as follows:

MIX	DEPTH in meters	DEPTH in feet
21%	13m	43ft
32%	6m	20ft
36%	4m	13ft

## WARNING

**Nitrox diving should only be attempted by experienced divers after proper training from an internationally recognized agency.**

## 3.2 Attention messages and alarms

The Aladin One draws the diver's attention to certain situations and warns of unsafe diving practices. These attention messages and alarms are visual and/or audible.

### 3.2.1 Attention messages

Attention messages are communicated visually using symbols, letters or flashing figures. In addition, 2 short audible sequences can be heard (in an interval of 4 seconds) in 2 different frequencies under water.

Attention messages come up in the following situations:

- Maximum operating depth/ppO<sub>2</sub> max is reached.
- Set max depth is reached.
- Oxygen toxicity reaches 75%.
- No-stop time is less than 3 minutes.
- Prohibited altitude (surface mode).
- Entering decompression.
- Half of set dive time is reached.
- Set dive time is reached.

### 3.2.2 Alarms

Alarms are provided visually by flashing symbols, letters or figures. In addition, an audible sequence in one frequency can be heard during the whole duration of the alarm.

An alarm occurs in the following situations:

- Oxygen toxicity reaches 100%.
- Ignored decompression.
- Exceeding the prescribed ascent rate.
- Altitude alarm.
- Low battery alarm (without audible alarm): battery icon appears if battery has to be replaced.

 *NOTE: Audible attention messages can be switched off in the watch settings mode (by pressing the right button 5x to the sounds screen) or in LogTRAK. With LogTRAK sounds can be switched off selectively or completely.*

#### WARNING

If you turn off all sound you will have no audible warnings. Without audible warnings you could inadvertently find yourself in potentially hazardous situations which could result in death or serious injury.

#### WARNING

Serious injury or death may result from failing to immediately respond to alarms provided by the Aladin One.

## 3.3 Preparation for the dive

It's important to check the settings of the Aladin One, especially before the first dive. All settings can be checked and changed directly on the Aladin One or by using LogTRAK and a PC.

### 3.3.1 Function check

To test the display, turn on your Aladin One with a press-and-hold of the left button. Are all elements of the display activated? Do not use your Aladin One if the display does not show all elements. (When switching on the Aladin One with the right button the test display will not appear.)

#### WARNING

Always check the battery capacity before each dive. See chapter: **System and Operation**, section: **Check the battery**.

### 3.3.2 Setting the gas mixture and $ppO_2$ max

To set the gas mixture, the Aladin One must be in the dive display (showing time of day, temperature and gas percentage):

1. Press-and-hold the right button to get to the GAS screen, then press-and-hold the right button again to get to the GAS 1  $O_2$  menu.

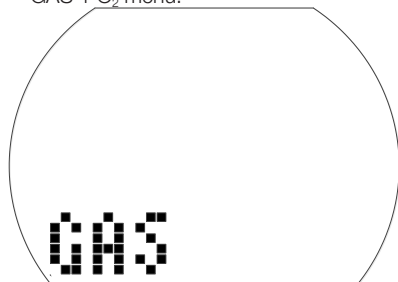

2. Confirm that you wish to change the oxygen fraction of gas 1 with a press-and-hold of the right button.
3. By pressing either the left or right button you can change the oxygen fraction in increments of 1%. The Aladin One will display the current fraction of oxygen, the maximum partial pressure limit ( $ppO_2$  max) and the MOD.
4. Confirm your selected percentage with a press-and-hold of the right button.
5. Next, by pushing the left or right button you can change the  $ppO_2$  max for your chosen fraction of oxygen down to 1.0bar. The Aladin One will now display the corresponding MOD for the new  $ppO_2$  max.
6. Confirm your  $ppO_2$  max setting with a press-and-hold of the right button.

 *NOTE: Without confirmation via a press-and-hold of the right button the display will disappear after 3 minutes and your entries will not be accepted. Automatic reset of the  $O_2\%$  mix to 21% can be set between 1 and 48 hours or to "no reset" (default).*

## ⚠ WARNING

Before every dive and after changing the tank, make sure that the settings for the gas mixture correspond to the current mixture being used. An incorrect setting will cause the Aladin One to miscalculate the dive. If the fraction of oxygen is set too low, oxygen poisoning can occur without warning. If the value is set too high, decompression sickness may occur. Inaccuracies in the calculations are carried over to repetitive dives.

### 3.4 Functions during the dive

#### 3.4.1 Alternate displays

By pushing the right button during the dive you can scroll through the alternate displays (Max depth > Temperature > Time, Temperature).

You can get back to the first display by:

- Scrolling with the right button through the displays.
- Without taking any action, after 5 seconds the display automatically switches back to the original display.

#### 3.4.2 Dive time

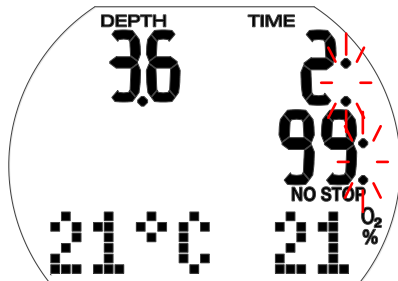

All time spent below a depth of 0.8m/3ft is displayed as dive time in minutes. The time spent above 0.8m/3ft is counted as dive time only if you once again descend below 0.8m/3ft within 5 minutes.

While the dive time is running, the colons to the right of the figures are flashing in 1-second intervals.

The maximum dive time displayed is 199 minutes. If a dive lasts longer than 199 minutes the dive time display starts again at 0 minutes.

NOTE: Half time alarm (turn around alarm): If half of the set maximum dive time has elapsed, an audible signal will sound and the symbol flashes for 1 minute.

When the set dive time has elapsed an audible alarm sounds and the dive time starts flashing.

#### 3.4.3 Current depth/O<sub>2</sub>% mix

Current depth is given in 10cm increments in the metric setting and 1ft increments in the imperial setting.

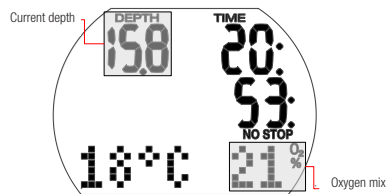

At a diving depth of less than 0.8m/3ft the display shows " --- ".

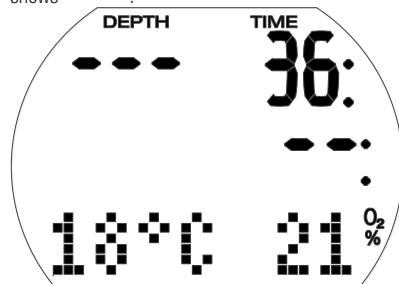

#### 3.4.4 Max depth/Temperature

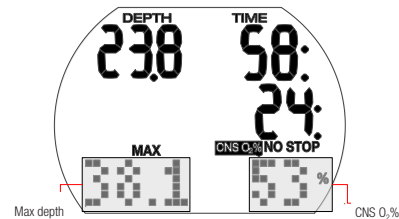

Max depth is displayed only if it exceeds the current depth by more than 1m/3ft (maximum indicator function). In the absence of max depth the Aladin One displays temperature.

The O<sub>2</sub>% mix is displayed as long as the CNS O<sub>2</sub>% is less than 50%. More than 50% and the CNS O<sub>2</sub>% is displayed.

### 3.4.5 Set max depth reached

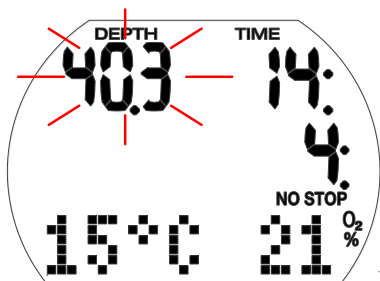

#### ⚠ WARNING

If the set max depth has been reached (default 40m/130ft) and the depth alarm is turned on, the alarm tone sounds and the depth display flashes. Ascend until the depth stops flashing.

### 3.4.6 Ascent rate

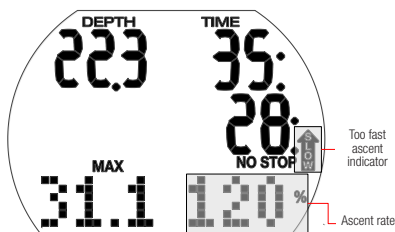

Optimal ascent rate varies depending on depth between 7 and 20m/min (23 and 67ft/min). It is displayed as a percent of the reference variable ascent rate. If the ascent rate is greater than 100% of the set value, the vertical black arrow with "SLOW" appears. If the ascent rate exceeds 140%, the arrow starts flashing.

The Aladin One provides an audible alarm if the ascent rate is 110% or greater. The intensity of the alarm increases in direct proportion to the degree that the prescribed ascent rate is exceeded.

#### ⚠ WARNING

The prescribed ascent rate must be observed at all times! Exceeding the prescribed ascent rate can lead to microbubbles in the arterial circulation which can lead to serious injury or death due to decompression sickness.

- In case of an improper ascent the Aladin One may require a decompression stop, even within the no-stop phase, because of the danger of microbubble formation.
- The decompression duration necessary for the prevention of microbubbles can increase massively if the ascent rate is exceeded.
- From great depths a slow ascent may cause heightened saturation of tissues and an extension of both decompression duration and total ascent time. At shallow depths, a slow ascent may shorten the decompression duration.
- Display of the ascent rate has the priority over "CNS O<sub>2</sub>".

Excessive ascent rates for longer periods are entered in the logbook. The following ascent rates correspond to the 100% value in the Aladin One.

DEPTH		ASC SPEED	
m	ft	m/min	ft/min
0	0	7	23
6	20	8	26
12	40	9	29
18	60	10	33
23	75	11	36
27	88	13	43
31	101	15	49
35	115	17	56
39	128	18	59
44	144	19	62
50	164	20	66

### 3.4.7 Partial pressure of oxygen (ppO<sub>2</sub> max)/Maximum operating depth (MOD)

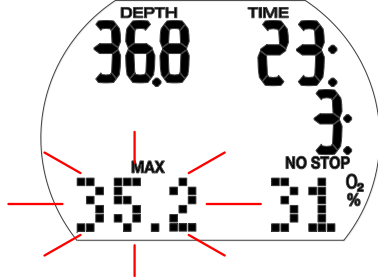

The maximum partial pressure of oxygen (ppO<sub>2</sub> max), with a default of 1.4bar, determines the Maximum Operating Depth (MOD). Diving deeper than the MOD exposes you to oxygen partial pressures higher than the set maximum level.

The ppO<sub>2</sub> max, and consequently the MOD, can be reduced manually when setting the gas. See chapter: **Settings**, section: Gas menu.

#### ⚠ WARNING

The MOD is a function of ppO<sub>2</sub> max and the mixture used. If during the dive the MOD is reached or exceeded, the Aladin One sends an audible attention message and the MOD is displayed (flashing) in the lower left corner. If this occurs, ascend to a depth shallower than the displayed MOD in order to diminish the danger of oxygen poisoning.

#### ⚠ WARNING

The MOD should not be exceeded. Disregarding the warning can lead to oxygen poisoning.

### 3.4.8 Oxygen toxicity (CNS O<sub>2</sub>%)

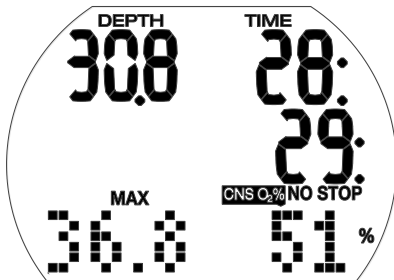

The Aladin One calculates oxygen toxicity based on depth, time and gas mixture, and displays it in the lower right corner when the value is greater than 50%. The toxicity is expressed in 1% increments of a maximum tolerated value (CNS O<sub>2</sub> clock).

The symbol “CNS O<sub>2</sub>” is displayed together with the percentage.

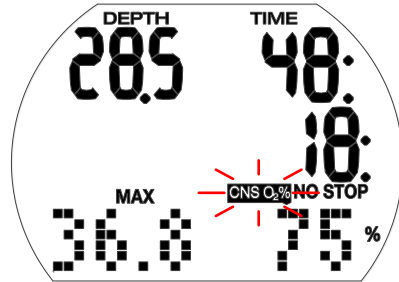

#### ⚠ WARNING

An audible attention signal starts if oxygen toxicity reaches 75%. The symbol “CNS O<sub>2</sub>%” flashes.

Ascend to a shallower depth to decrease oxygen loading, and consider terminating the dive.

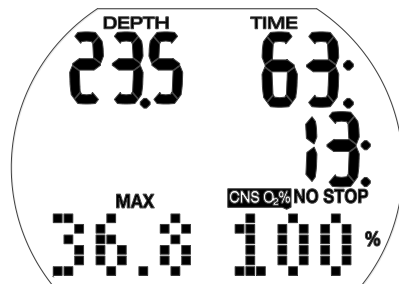

#### ⚠ WARNING

When oxygen toxicity reaches 100%, an audible alarm sounds every 4 seconds. “CNS O<sub>2</sub>” and the percentage value flash, indicating the danger of oxygen toxicity! Start procedure for terminating the dive.

📖 NOTE:

- During an ascent, and if the CNS O<sub>2</sub>% value does not increase (due to a lower partial pressure of oxygen), the audible warning is suppressed.



- During an ascent, the display of the oxygen toxicity is replaced by the ascent rate. If the ascent is stopped, the display changes back to the indication of the CNS value.
- The Aladin One displays CNS O<sub>2</sub>% values exceeding 199% with 199%.
- The Aladin One displays CNS O<sub>2</sub>% values above 50%.

### 3.4.9 Decompression information

NO STOP and the no-stop time (in minutes) are displayed if no decompression stops are necessary.

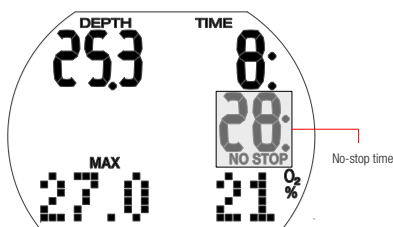

**NOTE:**

- A no-stop display of "99:" means there is remaining time of 99 minutes or more.
- No-stop time is influenced by the water temperature.

### ⚠ WARNING

If no-stop time drops below 3 minutes, an audible attention signal is activated and the no-stop value begins to flash. If no-stop time is less than 1 minute, the no-stop display shows the flashing value "0".

In order to prevent a decompression dive, ascend slowly until the no-stop time is 5 minutes or more.

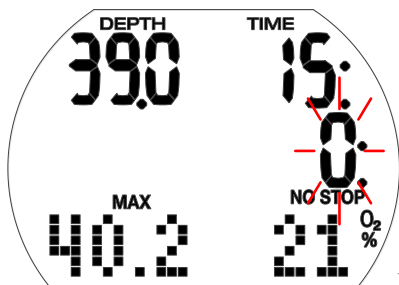

### ⚠ WARNING

Decompression diving requires advanced training from a recognized agency. Do not attempt decompression diving without proper training from a recognized agency.

### 3.4.10 Decompression values

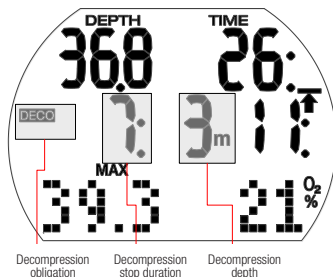

On entering the decompression phase, "NO STOP" disappears, "DECO" appears and the audible attention beep sounds. The "STOP" arrow appears next to the "DECO" symbol when the diver is at decompression range (1.5m / 5ft below the stop).

The deepest decompression stage in meters/feet is displayed and the decompression stop duration of the displayed stage appears in minutes. The display "7: 3m" means that a decompression stop of 7 minutes at a depth of 3m/10ft has to be made.

When a decompression stop has been completed, the next (shallower) decompression stop is displayed.

When all decompression stops have been completed, the "DECO STOP" symbol disappears and the "NO STOP" symbol along with the no-stop time reappears.

Deco stop depths deeper than 27m/90ft are displayed as "-- : --".

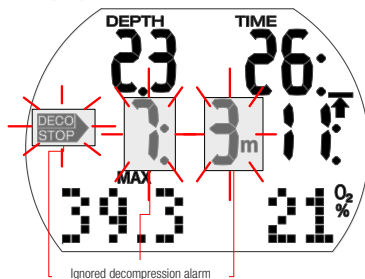

## ⚠ WARNING

The decompression alarm is activated if the decompression stop is ignored. The “DECO STOP” arrow, the decompression stop duration, and the decompression stop depth begin to flash and an audible alarm sounds. Due to the formation of microbubbles, decompression can increase massively if a decompression stop is ignored. Descend to the prescribed decompression stop depth immediately!

When the surface is reached during the decompression alarm, the “DECO STOP” arrow, the decompression stop duration, and decompression stop depth continue flashing in order to point to the risk of a decompression accident. The SOS mode is activated 3 minutes after the dive if corrective action is not taken. If the total (cumulative) duration of the decompression alarm is longer than one minute, it is entered in the logbook.

### 3.4.11 Total ascent time

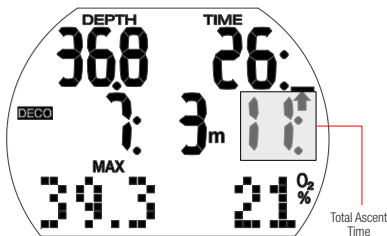

As soon as decompression stops are necessary, the Aladin One shows the total time of ascent. This includes the ascent time from the current depth to the surface as well as all decompression stop obligations.

👉 **NOTE:** The total time of ascent is calculated on the basis of the prescribed ascent rate. Total time of ascent can be subject to change if the ascent rate is not ideal (100%). Ascent time greater than 99 minutes is displayed as “--”.

## ⚠ WARNING

On all dives with the Aladin One, make a safety stop for at least 3 minutes at a depth of 5m/15ft.

### 3.4.12 Safety stop timer

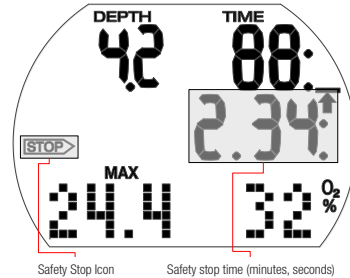

The safety stop timer displays the time a diver should spend at the safety stop depth at the end of the dive. The timer starts automatically when depth is shallower than 5m/15ft and counts back from 3 minutes (default) to zero. It can be restarted manually any number of times. The duration of the timer can be set between 1 and 5 minutes.

The safety stop timer will be activated under the following conditions: depth <5m/15ft; no-stop display of 99 min; stop time is selected (1-5 min) in the scuba mode menu.

You can activate the safety stop timer by pressing the left button. The timer begins to count backwards. If you press again, the timer will start again from the full value.

The safety stop timer will switch off automatically if the depth exceeds 6.5m/21ft or the no-stop phase is shorter than 99 minutes.

## 3.5 Functions after the dive

### 3.5.1 End of a dive

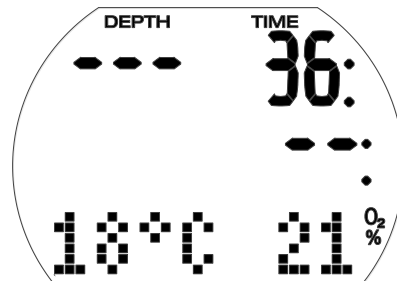

After reaching the surface (<0.8m/3ft) the Aladin One remains in dive mode for 5

minutes. The delay allows for surfacing for a short period for orientation.

After 5 minutes, the dive is closed and is entered into the logbook. The desaturation time, the no-fly time, the no-dive warning (if applicable), the current altitude class and the prohibited altitude class are displayed for 3 minutes, after which the computer turns off.

### ⚠ WARNING

For calculations of desaturation and no-fly time it is assumed that you are breathing air while on the surface.

#### 3.5.2 Desaturation time, No-fly time and No-dive warning

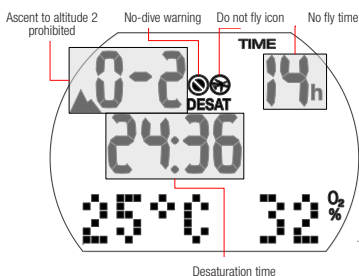

5 minutes after a dive the Aladin One shows the desaturation time, the no-fly time, the no-dive warning (if applicable), the current altitude class and the prohibited altitude class – see chapter: **Diving with your Aladin One**, section: **Prohibited altitude**.

No-fly time is the time in hours that should pass before flying. It is displayed until the value counts down to 0 hours.

### ⚠ WARNING

Flying while the Aladin One displays the “do not fly” icon may lead to serious injury or death from decompression sickness.

### ⚠ WARNING

If the “no-dive” warning is visible during the surface interval, you should not undertake another dive.

To check the elapsed surface interval and oxygen toxicity, press-and-hold the right button.

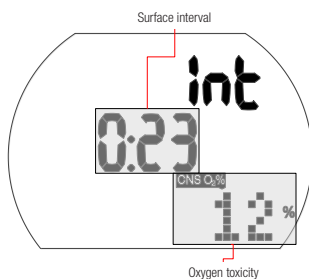

Desaturation time is determined either by oxygen toxicity, nitrogen saturation or the regression of microbubbles, depending on which requires the longer time.

#### No-dive warning

If the Aladin One detects a situation of increased risk (due to the potential of microbubble accumulation from previous dives or a CNS O<sub>2</sub> level above 40%), the “no-dive” symbol will appear on the display.

The duration of the no-dive warning is visible in the dive planner menu. The Aladin One recommends this as a minimum surface interval in order to reduce the number of microbubbles and/or to reduce the CNS O<sub>2</sub> level below 40%.

**NOTE:** You should not undertake a dive as long as the no-dive warning message is displayed on the computer screen. If the warning is prompted by microbubble accumulation (as opposed to CNS O<sub>2</sub> over 40%) and you dive anyway, you will have shorter no-stop times or longer decompression times. Moreover, the duration of the no-dive warning at the end of the dive can increase considerably.

## 3.6 Diving in mountain lakes

### 3.6.1 Altitude classes

The Aladin One measures the atmospheric pressure every 60 seconds, even while the display is switched off. If the computer detects a sufficient increase in altitude, it switches on automatically and indicates the new altitude class (1-4) and the desaturation time. Desaturation time indicated at this moment refers to the adaptation time at this altitude. If the dive starts within this adaptation time, the Aladin One treats it as a repetitive dive, since the body is off-gassing.

Altitude is divided into 5 classes, which are influenced by barometric pressure. That is why the defined altitude classes overlap on their fringes. If a mountain lake is reached, the altitude class is indicated at the surface (time of day display), in the logbook and in the dive planner with a stylized mountain icon and the current altitude class. The altitude from sea level to approximately 1000m/3280ft is not indicated. In the following diagram, you can see the approximate breakdown of the altitude classes:

Altitude Class	Elevation	Barometric switch point	Dive computer mode
C4	4000 m	610 mbar	GAUGE (no deco data)
	13120 ft	8.85 psi	
C3	3000 m	725 mbar	SCUBA
	9840 ft	10.51 psi	
C2	2000 m	815 mbar	SCUBA
	6560 ft	11.82 psi	
C1	1000 m	905 mbar	SCUBA
	3280 ft	13.13 psi	
C0	0 m	0 ft	SCUBA

### 3.6.2 Prohibited altitude



Ascent to altitude class 3 and 4 is prohibited. Maximum allowed altitude: 2650m/8694ft.

#### WARNING

**At the surface, the Aladin One shows, via flashing altitude class number, the altitude to which you may not rise. The ascent prohibition is displayed together with the current altitude class.**

Example:



You are at 1200m/3937ft (altitude class 1) and you may ascend to class 2 only (2650m/8694ft). You may not rise to the altitude classes 3 or 4.

#### WARNING

**If an ascent to a prohibited altitude is detected, an audible alarm sounds for 1 minute. Descend to a lower altitude.**

### 3.6.3 Decompression dives in mountain lakes

In order to assure optimal decompression even at higher altitudes, the 3m/10ft decompression stage is divided into a 4m/13ft stage and a 2m/7ft stage in altitude classes 1, 2 and 3. The prescribed decompression stop depths are in sequence (2m/7ft, 4m/13ft, 6m/20ft, 9m/30ft...).

If atmospheric pressure is below 620mbar/8.99psi (altitude higher than 4100m/13450ft above sea level), no decompression data is calculated and displayed (automatic gauge mode). In addition, the dive planner is no longer available.

## 4. FUNCTIONS ON THE SURFACE

### 4.1 Dive planner

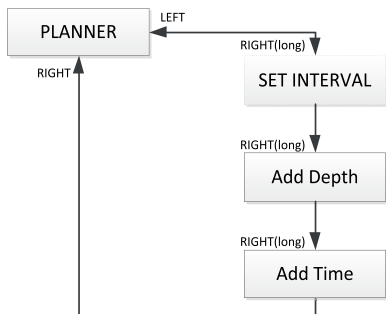

The Aladin One has a dive planner which allows the planning of no-stop dives and decompression dives. The following elements are included as the basis for dive planning:

- Selected fraction of oxygen and MOD.
- Selected water type.
- Water temperature of the most recent dive.
- Altitude class (if any).
- Status of saturation at the time the dive planner is selected.
- Assumption: a normal diver workload and observance of the prescribed ascent rates.

#### 4.1.1 Planning a no-stop dive

To select the dive planner the Aladin One must start in the time of day display.

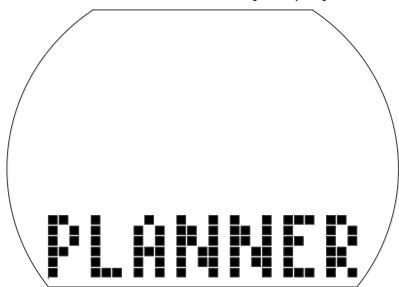

- Push the left or right button until the symbol for the dive planner appears. Enter the dive planner with a press-and-hold of the right button.

- The input window for the time interval is displayed if any desaturation (DESAT) remains before selecting the dive planner. This surface interval, timed between now and the beginning of the planned dive, can be changed in increments of 15 minutes by pressing the left or right button.
- The Aladin One displays the CNS O<sub>2</sub>% value and the altitude class to which you may not rise at the end of the selected surface interval.



- If the no-dive warning\* and its duration has been displayed, the Aladin One proposes this time – rounded up to the next 15 minutes – as surface interval. If the proposed interval is shortened, the no-dive warning\* appears.



- Confirm the displayed interval (if applicable) with a press-and-hold of the right button.

If no desaturation is remaining, the original press-and-hold from the PLANNER screen takes you directly to depth/no-stop planning:

- Pushing the left or right button selects the depth and the no-stop time for that depth.
- Depths deeper than the MOD for the selected gas (O<sub>2</sub> mix) are not displayed.

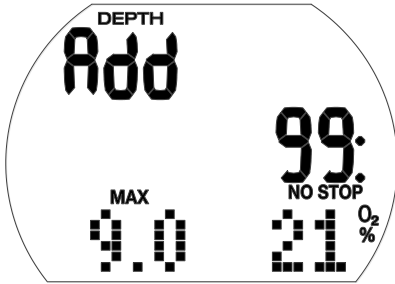

☞ **NOTE:** The no-dive warning and its duration are displayed if the Aladin One detects an increased risk due to the accumulation of microbubbles.

\* For more information and safety considerations regarding the no-dive warning, see chapter: **Diving with your Aladin One**, section: **Desaturation time, No-fly time and No-dive warning**.

#### 4.1.2 Planning a decompression dive

1. Activate the dive planner.
2. Set the desired depth by pressing the left or right button and then confirming with a press-and-hold of the right button. The Aladin One shows the bottom time (no-stop time + 1 minute) and the appropriate decompression information or level stop data, respectively.
3. "Add" asks that you set the bottom time. This is done by pressing the left or right button. The Aladin One calculates the decompression information for this set bottom time.

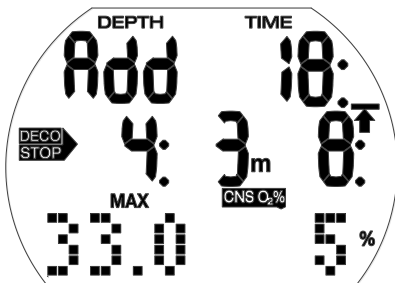

CNS O<sub>2</sub>% values higher than 199% will be displayed as 199%.

Ascent time greater than 99 minutes is displayed as "--".

Deco stop depth deeper than 27m/90ft is displayed as "--:--".

CNS O<sub>2</sub> equal or greater than 75%: CNS O<sub>2</sub>% symbol starts flashing.

CNS O<sub>2</sub> equal or greater than 100%: CNS O<sub>2</sub>% symbol and CNS O<sub>2</sub>% value are flashing.

#### 4.1.3 Leaving the dive planner

By pressing-and-holding the right button at the time field you can exit the dive planner. This will also occur after 3 minutes without operation.

## 4.2 Logbook

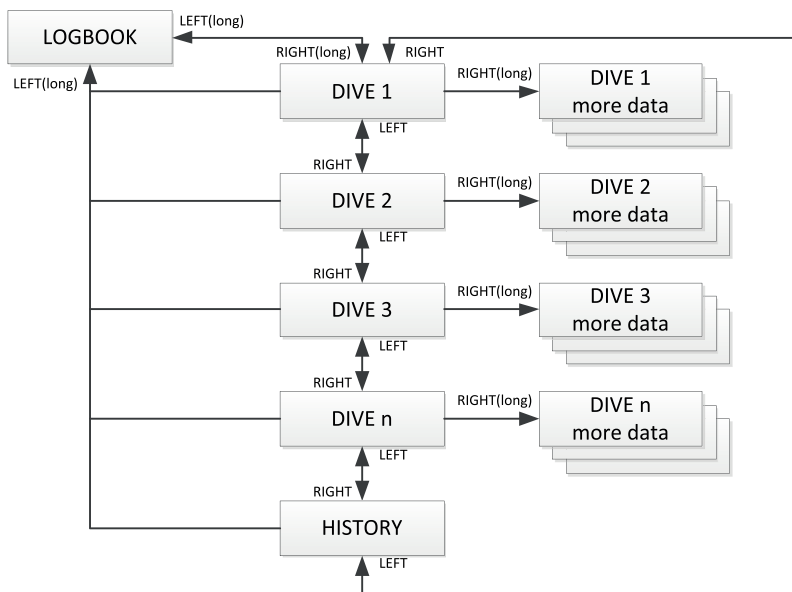

### 4.2.1 Survey

A dive is entered in the logbook if the dive time is longer than 2 minutes. The Aladin One records the profiles of about 25 hours of diving.

This information can be transferred to a PC with the Bluetooth interface and LogTRAK. All dives in the memory can be displayed directly on the dive computer.

### 4.2.2 Operation

From the time of day display you can select the logbook by pressing the left or right button until the following logbook menu appears:

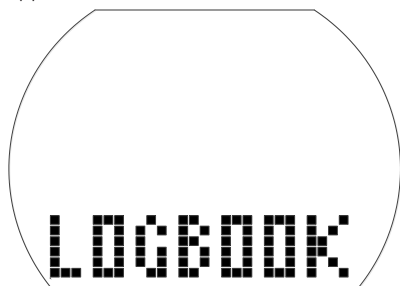

- With a press-and-hold of the right button you enter the logbook.
- By pressing the left or right button you can scroll through the different logged dives, which are numbered 1, 2, 3, etc., with the most recent dive shown as dive number 1.
- Primary information from each dive (max depth, dive time, date) is shown on page 1 of the log. More information on the dive are shown on page 2 and page 3.
- From page 1, page 2 can be accessed by a press-and-hold of the right button.
- From page 2, page 3 can be accessed by pressing the right button.
- Press again the right button to return on page 1.

#### 4.2.2.1 Page 1

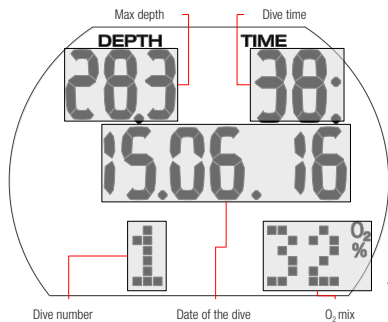

#### 4.2.2.2 Page 2

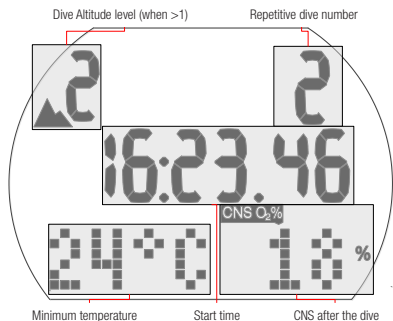

#### 4.2.2.3 Page 3

If a dive is started within adaptation time (after a change of altitude), the adaptation time is displayed instead of the surface interval.

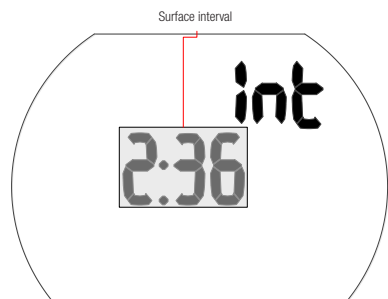

Further possible information about the dive:  
Too fast ascent\* (page 1).

**STOP DECO** Ignored decompression stop\* (page 1).

Diving in SOS mode (gauge mode) (page 3).  
Altitude class (page 2).

DESAT Desaturation was reset before the dive (in USER menu) (page 1, 2).

Battery quality factor has been 3 bars or less during the dive (page 1, 2, 3).

AVG Average depth (gauge mode) (page 3).

No-dive warning after the dive (page 1).

\*Alarms during the dive.

Pushing the right button gets you back to the dive list (first level screen within logbook). From here you can advance to the next dive of interest by pushing the right button, and then a press-and-hold of the right button lets you retrieve more information about that dive, etc.

#### 4.2.2.4 Statistical information (HISTORY)

The history page is located between the last and first log in the round-robin list of dives.

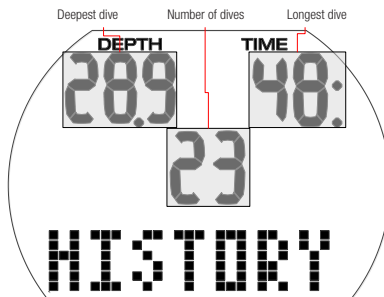

#### Leaving the logbook

By pushing-and-holding the left button you can exit the logbook. The logbook will also close automatically after 3 minutes without operation.



## 5. SETTINGS

### 5.1 Dive menu

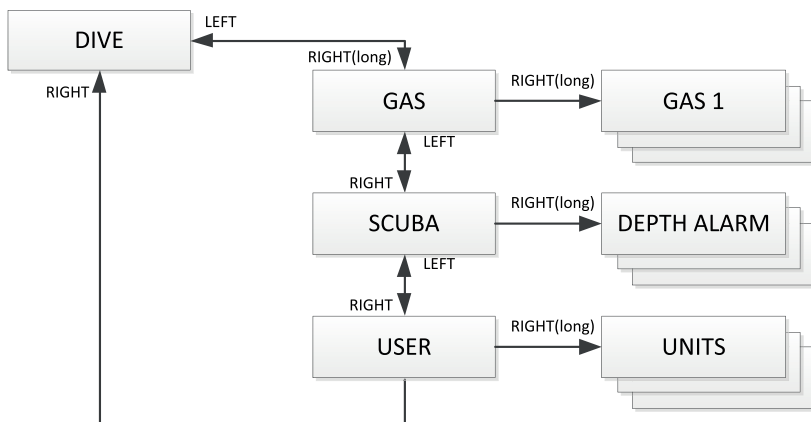

With the dive display menu or with LogTRAK you can configure the following items:

#### Setting Range; Default Setting

- Depth alarm: 5-100m/20-330ft, on/off; 40m/130ft, off.
- Dive time alarm: 5-195min, on/off; 60min, off.
- Safety stop duration: 1-5min; 3min.
- Maximum partial pressure of oxygen (ppO<sub>2</sub> max): 1.0 - 1.6bar; OFF; 1.4bar.
- Time limit to reset the O<sub>2</sub>% mix to air: no reset/1-48hrs; no reset.
- Unit system: metric/imperial; no default.
- Water type: on (salt water)/off (fresh water); on (salt water).
- Audible attention signals: on/off (LogTRAK: selective); on.
- Reset desaturation: on/off; no reset.

Starting from the time of day display, press the left or right button until dive display is shown:



Enter the dive display menu with a press-and-hold of the right button. Once entered you can scroll through the menu by pressing the left or right button.

### 5.1.1 Gas menu

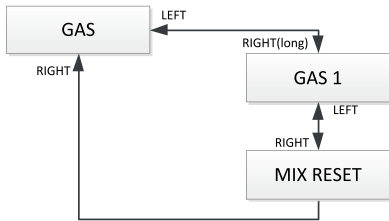

In the gas menu you can change nitrox mix settings.

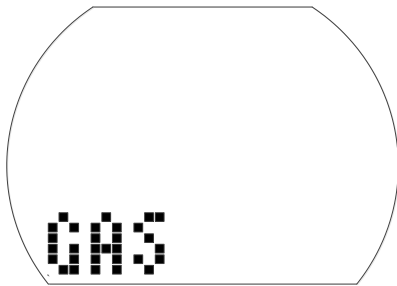

#### Setting the GAS 1

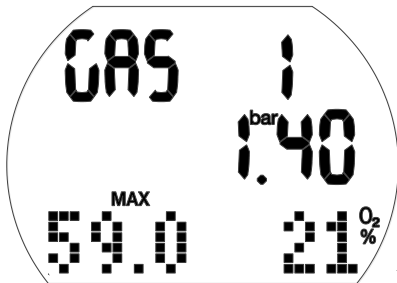

1. Confirm that you wish to change the GAS 1 content with a press-and-hold of the right button.  
Gas nitrox value (O<sub>2</sub>%) starts to flash.
2. Press the left or right button to increase/decrease in 1% increments.
3. Confirm content with a press-and-hold of the right button.  
The ppO<sub>2</sub> values.
4. Change the ppO<sub>2</sub> value in increments of 0.05bar by pressing the right button.
5. Confirm the value with a press-and-hold of the right button.

### Setting the nitrox reset time

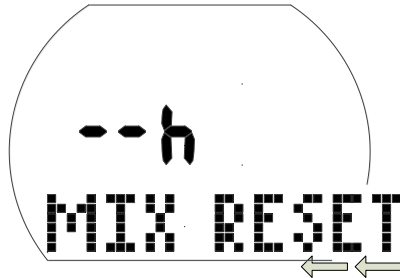

#### Setting the time limit to reset the O<sub>2</sub> mix to air

1. Confirm that you wish to change the time limit of the reset with a press-and-hold of the right button.  
The current setting starts to flash.
2. Change the time limit by pushing the left or right button (1- 48hrs or no reset: “- - h”).
3. Confirm the selected value with a press-and-hold of the right button.

### 5.1.2 Scuba menu

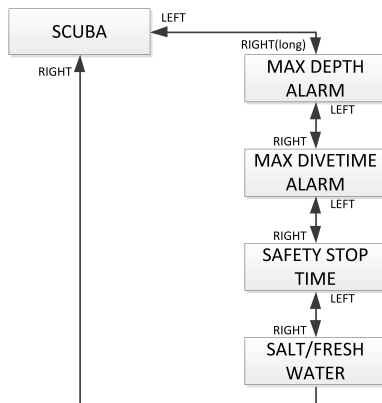

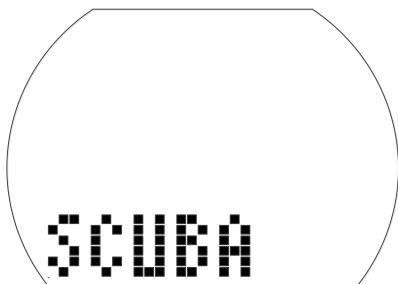

In the scuba menu you can change different alarms and settings for the dive.

### Setting the depth alarm

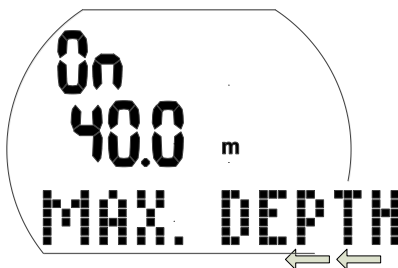

1. Confirm that you wish to change the depth of the warning, or switch it on or off, with a press-and-hold of the right button.  
"On" or "Off" starts to flash. "On" indicates "activated", "Off" indicates "deactivated".
2. Press the left or right button to switch between "On" and "Off".
3. Confirm the selected status with a press-and-hold of the right button.  
The depth starts to flash.
4. Change the warning depth in increments of 1m/5ft by pressing the right button.
5. Confirm the warning settings with a press-and-hold of the right button.

### Setting the dive time alarm

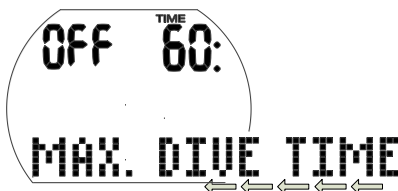

1. Confirm that you wish to change the time of the dive time warning, or switch

it on or off, with a press-and-hold of the right button.

"On" or "Off" starts to flash. "On" indicates "activated", "Off" indicates "deactivated".

2. Switch between "On" or "Off" by pressing the left or right button.
3. Confirm the selected status with a press-and-hold of the right button.  
The alarm time starts to flash.
4. Change the warning time in increments of 5 minutes by pressing the right button.
5. Confirm the warning settings with a press-and-hold of the right button.

### Setting the safety stop duration

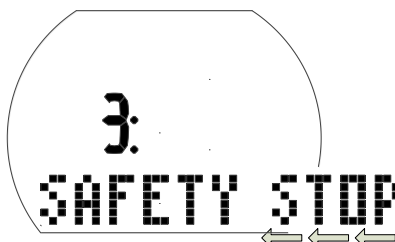

1. Confirm that you wish to change the duration of the safety stop with a press-and-hold of the right button.  
The duration starts to flash.
2. Change the duration in increments of 1 minute by pressing the left or right button.
3. Confirm the selected duration with a press-and-hold of the right button.

### Selecting water type



Selecting the water type

1. Confirm that you wish to change the selected water type with a press-and-hold of the right button.  
"On" or "Off" starts to flash. "On" indicates salt water, "Off" indicates fresh water.

2. Switch between “On” and “Off” by pressing the left or right button.
3. Confirm the water type with a press-and-hold of the right button.

**NOTE:** Water type has an effect on displayed depth. Roughly, 1bar/14.5psi water pressure corresponds to 10m/33ft depth in salt water and 10.3m/34ft depth in fresh water.

### 5.1.3 User menu

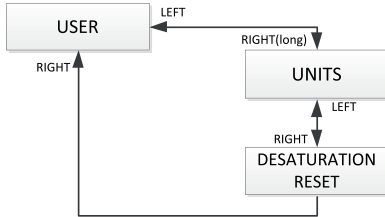

#### Selecting the units

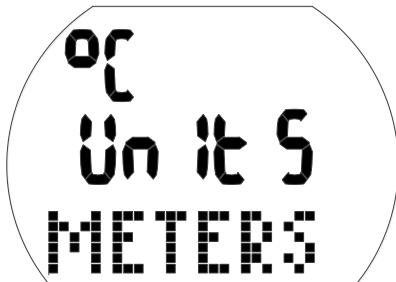

1. Confirm that you wish to change the units with a press-and-hold of the right button.
- “°C” or “°F” starts to flash.
2. Switch between “°C” and “°F” by pressing the left or right button.
  3. Confirm the selected unit with a press-and-hold of the right button.
- Meters or Feet start to flash.
4. Switch between meters or feet by pressing the left or right button.
  5. Confirm the selected unit with a press-and-hold of the right button.

#### Resetting the remaining saturation

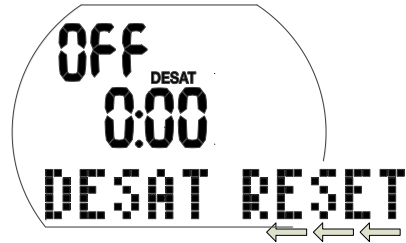

#### **WARNING**

- Diving after a reset of the remaining saturation may lead you into potentially hazardous situations which could result in death or serious injury. After a reset of the remaining saturation do not dive for at least 48 hours.
- If you dive after resetting the remaining saturation the computer will miscalculate your decompression, which may result in serious injury or death. Reset the remaining saturation only if you know you will not be diving, flying or going to higher altitude for the next 48 hours.
- Resetting the desaturation should only be done when there is a valid reason, e.g. loaning the computer to somebody who has not dived in 48 hours or more. When the computer itself has remaining saturation you must assume full responsibility for the consequences of resetting the remaining saturation.

1. Confirm that you wish to reset the displayed saturation with a press-and-hold of the right button.
- “On” starts to flash.
2. Switch between “On” or “Off” by pressing the left or right button.
  3. Confirm the setting with a press-and-hold of the right button.
- If you have selected “Off”, “Code” and “000” appear.
4. Set the first digit by pressing the left or right button. Confirm with a press-and-hold of the right button.
  5. Repeat Step 4 for the next 2 digits.
- If you entered the right code the desaturation will be reset to zero (desat off). Code: 313.

## 5.2 Watch menu

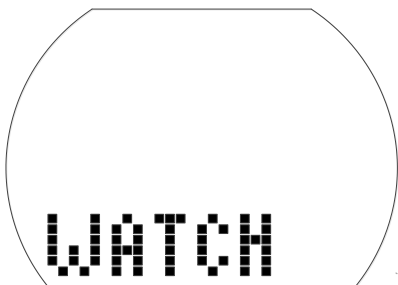
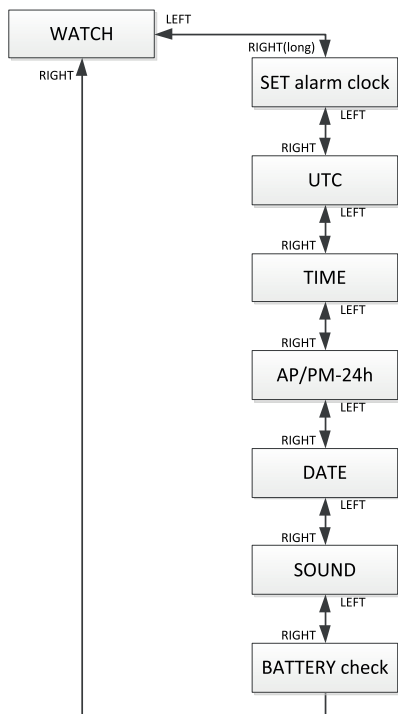

Using the watch menu or LogTRAK you can configure the following items:

Setting	Range	Default
Alarm clock		off
UTC (Universal Time Coordinated) zone	-13/+14hrs, increments: 15min	
24h or AM/PM setting		24h

Date		
Silent mode	On, warnings, alarms, off	on
Check the battery state		

1. Starting from the time of day display, press the left or right button until “WATCH” appears.
2. Confirm that you wish to enter into the watch menu with a press-and-hold of the right button.
3. Once entered you can scroll through the menu by pressing the left or right button.

### 5.2.1 Setting the alarm clock time



The alarm clock tone works only at the surface.

1. Confirm that you wish to set the alarm time with a press-and-hold of the right button.  
“On” (activated) or “Off” (deactivated) starts to flash.
2. Switch between “On” and “Off” by pressing the left or right button.
3. Confirm the selected status with a press-and-hold of the right button. The hours start to flash.

4. Set the hours by pressing the left or right button.
5. Confirm the setting with a press-and-hold of the right button.  
The minutes start to flash.
6. Set the minutes by pressing the left or right button.
7. Confirm the setting with a press-and-hold of the right button.

### 5.2.2 **Setting the UTC offset (coordinated universal time)**

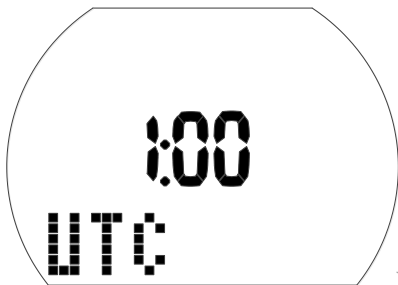

This setting allows you to quickly set the watch to a new time zone without affecting the actual time setting.

1. Confirm that you wish to set the UTC offset with a press-and-hold of the right button.  
The hours start to flash.
2. Set the hours by pressing the left or right button (-13/+14hrs).
3. Confirm the setting with a press-and-hold of the right button.  
The minutes start to flash.
4. Set the minutes in increments of 15 minutes by pressing the left or right button.
5. Confirm the selected status with a press-and-hold of the right button.

### 5.2.3 **Adjusting the time of day**



You can adjust the Aladin One to your time zone either in this menu or using the UTC offset (see above).

1. Confirm that you wish to adjust the time of day with a press-and-hold of the right button.  
The hours start to flash.
2. Set the hours by pressing the left or right button.
3. Confirm the setting with a press-and-hold of the right button.  
The minutes start to flash.
4. Set the minutes by pressing the left or right button.
5. Confirm the setting with a press-and-hold of the right button.

### 5.2.4 **Selecting 24-hour or AM/PM setting**



1. Confirm that you wish to change the setting with a press-and-hold of the right button.  
“On” or “Off” starts to flash.
2. Switch between “On” (AM/PM) and “Off” (24h) by pressing the left or right button.
3. Confirm the setting with a press-and-hold of the right button.

The 24h - AM/PM setting influences the display of the date (see below).

### 5.2.5 Adjusting the date

Date: Day/Month/Year (24h setting)



Date: Month/Day/Year (AP/PM setting)



1. Confirm that you wish to adjust the date with a press-and-hold of the right button.  
The day (or month) starts to flash.
2. Set the day (or month) by pressing the left or right button.
3. Confirm the setting with a press-and-hold of the right button.  
The month (or day) starts to flash.
4. Set the month (or day) by pressing the left or right button.
5. Confirm the setting with a press-and-hold of the right button.  
The year starts to flash.
6. Set the year by pressing the left or right button.
7. Confirm the setting with a press-and-hold of the right button.

### 5.2.6 Switching the sound on and off

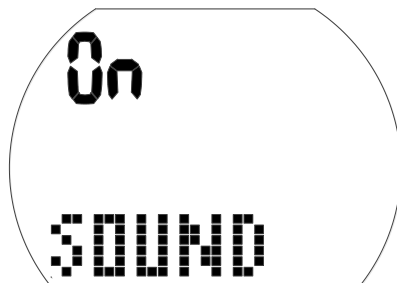

#### **⚠ WARNING**

If you turn off the sound, the buzzer is effectively deactivated. You will have no audible warnings (alarms and attention messages). Without audible warnings you could get into potentially hazardous situations, which could result in death or serious injury. You must assume full responsibility for turning off the sound.

1. Confirm that you wish to change the setting with a press-and-hold of the right button.  
“On”, “Off”, “Alr” or “Att” starts to flash. The “On” setting has all audible tones activated, including the button-pressing tone.  
The “Off” setting is the silent mode, without any tones, except the alarm clock.  
The “Alr” setting has alarm tones activated.  
The “Att” setting has alarm and attention tones activated.
2. Switch between selections by pressing the left or right button.
3. Confirm the setting with a press-and-hold of the right button.  
If you have selected “Off”, “Code” and “000” appear.
4. Set the first digit by pressing the left or right button. Confirm with a press-and-hold of the right button.
5. Repeat Step 4 for the next 2 digits. If you entered the right code the sound will be turned off. The Code: 313

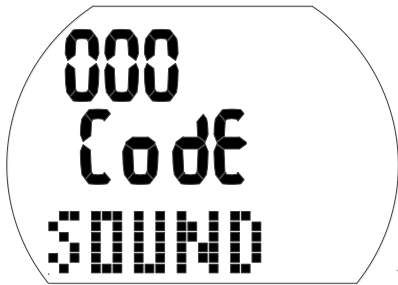

**NOTE:** Setting the sound to “off” applies also to surface functions (altitude alarm and change of altitude class).

### 5.2.7 Check the battery status



Battery status is shown in this menu. A fresh battery is indicated by 6 zeros, whereas a used battery is indicated by fewer zeros, as in below:



To learn more about battery status, see chapter: **System and Operation**, section: **Checking the battery condition**.

## 6. INTERFACING WITH WINDOWS/MAC AND APPS

### 6.1 Introduction to SCUBAPRO LogTRAK

LogTRAK is the software that allows the Aladin One to communicate with a Windows-based PC, a Mac, Android devices or Apple devices.

In order to take advantage of any of these features, you need to establish a communication between your PC and your Aladin One with a Bluetooth connection.

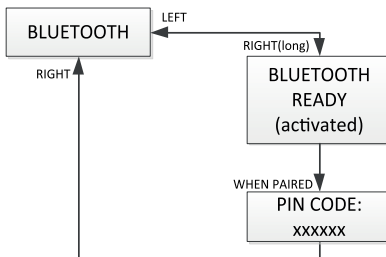

To start the communication:

1. If your PC/Mac has Bluetooth, enable it.
  - a. If your PC/Mac doesn't have a Bluetooth Low Energy (BLE), connect the suitable dongle to your PC/Mac.
2. Launch LogTRAK on your PC/Mac.
  - a. Select the Bluetooth. (Extras > Options > Download) Select the Bluetooth option.
3. Switch on the Aladin One.
4. Press the right button to get to the Bluetooth menu.

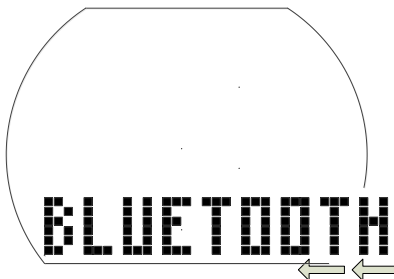



1. Press-and-hold the right button to activate Bluetooth advertising.

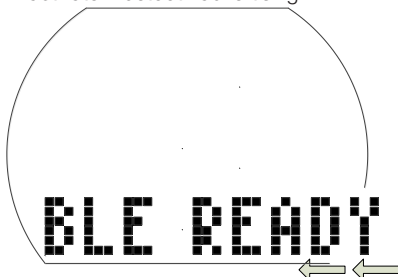

2. When a connection between your PC/Mac and Aladin One is established, the Aladin One will provide a 6-digit pin code.

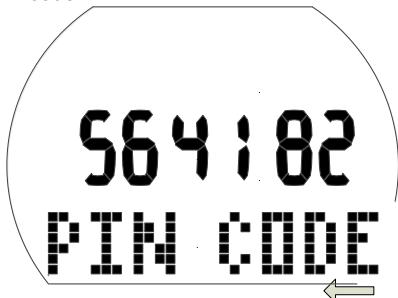

3. Give this code to your PC/Mac. Connection between both devices is ready.

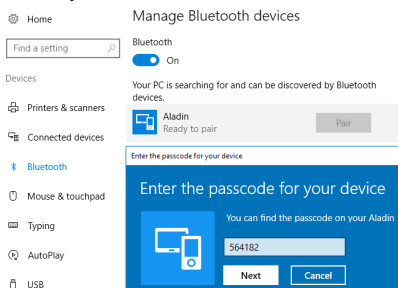

### Download dive profiles

From LogTRAK, by selecting Dive > Download Dives you can transfer the Aladin One logbook to your PC/Mac.

There are three main views, each showing a specific part of your dive log:

**Profile** shows the graphical data of the dive.



**Details** about the dive, where you can edit, for example, the equipment and tank information.

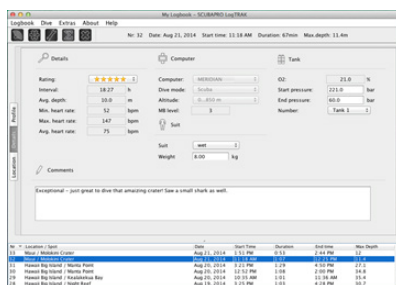

**Location** shows your dive site on the world map.

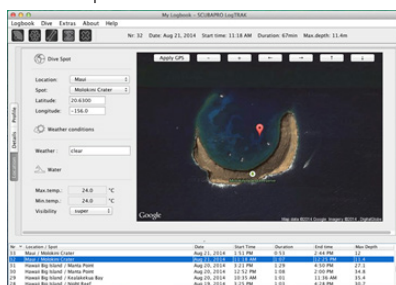

The selection tabs for views are on the left side of the main window.

## 6.2 Changing warnings/ settings of the Aladin One and reading computer information

By selecting Extras > Read Dive Computer settings you can enable/disable warnings that cannot be individually enabled or disabled by using the menus on the actual Aladin One unit.

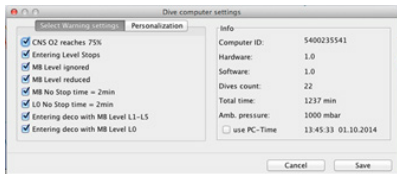

Read sections on warnings and alarms about the possible selections that you can modify on your Aladin One.

You may also change the shown units between metric/imperial. Select Extras > Options > Measurement Units:

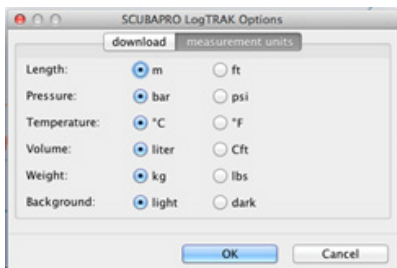

## 7. TAKING CARE OF YOUR ALADIN ONE

### 7.1 Technical information

Operating altitude:

With decompression – sea level to approximately 4000m/13300ft.

Without decompression above approx. 4000m (13000ft): automatic gauge mode (unlimited).

Max operating depth:

120m/394ft; resolution is 0.1m until 99.9m and 1m at depth deeper than 100m. Resolution in ft is always 1ft. Accuracy is within 2% ±0.3m/1ft.

Decompression calculation range:

0.8m to 120m/3ft to 394ft

Maximum environment pressure:

13bar/189psi

Clock:

Quartz; time, date, dive time display up to 199 minutes

Oxygen concentration:

Adjustable between 21% and 50%.

Operating temperature:

-10C to +50C/14F to 122F

Power supply:

CR2450 lithium battery

Life of the battery:

Estimated 2 years or 300 dives, whichever comes first. Actual battery life depends on the number of dives per year, the length of each dive, the water temperature and the usage of the backlight.

### 7.2 Maintenance

The depth accuracy of your Aladin One should be verified every 2 years and can be done by an authorized SCUBAPRO dealer. Aside from that, the Aladin One is virtually maintenance-free. All you need to do is rinse it carefully with fresh water after each dive and change the battery when needed. To avoid possible problems with your Aladin One, the following recommendations will help ensure years of trouble-free service:

- Avoid dropping or jarring your Aladin One.
- Do not expose your Aladin One to intense, direct sunlight.
- Do not store your Aladin One in a sealed container; always ensure that there is ample ventilation.
- If there are problems with the water contacts, use soapy water to clean your Aladin One and dry it thoroughly. Do not use silicone grease on the water contacts!
- Do not clean your Aladin One with liquids containing solvents.
- Check the battery capacity before each dive.
- If the battery warning appears, replace the battery.
- If any error message appears on the display, take your Aladin One to an authorized SCUBAPRO dealer.

### 7.2.1 Replacing the battery

(Use only the original SCUBAPRO battery kit with O-ring.)

The change must be made with particular care in order to prevent water from seeping inside. The warranty does not cover damage due to the improper replacement of the battery.

#### **⚠ WARNING**

**Never touch the metal surface of the battery with bare fingers. The 2 battery poles must never be short-circuited.**

#### **⚠ WARNING**

- A leaking battery cap may lead to the destruction of your Aladin One by water seeping in, causing your Aladin One to switch off without prior notice.
- Always open the battery compartment in a dry and clean environment.
- Only open the battery compartment to replace the battery.



Battery-changing procedure:

1. Dry your Aladin One with a soft towel.
2. Turn the battery cap with a coin or with a SCUBAPRO universal tool.
3. Remove the battery cap.
4. Remove the O-ring carefully. Do not damage the sealing surfaces.
5. Remove the battery. Do not touch the contacts.
6. Always insert a new O-ring when replacing the battery, and dispose of the old O-ring. Make sure that the new O-ring is in perfect condition, and that the O-ring, the O-ring groove and the sealing surfaces are free of dust and dirt. If necessary, clean the parts with a soft cloth. Fit the O-ring into the O-ring groove of the battery cap.

#### **⚠ WARNING**

**If you notice traces of seeping water, damage, or other defects on the O-ring, do not use your Aladin One for further dives. Take it to an authorized SCUBAPRO dealer for inspection and repair.**

#### **⚠ WARNING**

7. Use only an original SCUBAPRO O-ring. This O-ring is Teflon-coated and does not require additional lubrication.
8. Do not lubricate the O-ring as the lubricant will chemically attack the battery cap.

## **⚠ WARNING**

- Before installing, check the proper polarity of the battery. Your Aladin One can be damaged if you do not insert the battery correctly. Insert the new battery with the “+” facing outwards. Once the battery is replaced the Aladin One will perform an automatic test (8secs) and a short beep will sound when the test is done.



## **⚠ WARNING**

- The battery cap can be installed with a  $\pm 120^\circ$  offset. Push the battery cap firmly down and turn it clockwise until the 2 circles are aligned. The alignment circles are there to ensure proper positioning of the cap. If the rotation is stopped before alignment, water-tightness may not be ensured. If the rotation is forced beyond the alignment, the cap may break. Damage due to improper placement of the battery cap is not covered by the warranty.
- Check your Aladin One by switching it on.

*NOTE: Protect the environment and dispose of the battery properly.*

## **8. APPENDIX**

### **8.1 Warranty**

The Aladin One has a 2-year warranty covering defects in workmanship and function. The warranty only covers dive computers purchased from an authorized SCUBAPRO dealer. Repairs or replacements during the warranty period do not extend the warranty period itself.

Excluded are faults or defects due to:

- Excessive wear and tear.
- External influences, e.g. transport damage, damage due to bumping and hitting, influences of weather or other natural phenomena.
- Servicing, repairs or the opening of the dive computer by anybody not authorized by the manufacturer.
- Pressure tests which do not take place in water.
- Diving accidents.
- Improper placement of the battery cap.

For European Union markets, the warranty of this product is governed by European legislation in force in each EU member state.

All warranty claims must be returned with dated proof-of-purchase to an authorized SCUBAPRO dealer. Visit [www.scubapro.com](http://www.scubapro.com) for the dealer nearest you.



Your dive instrument is manufactured with high-quality components that can be recycled and reused. Nevertheless, these components, if not properly managed in accordance with the regulations on electrical and electronic equipment waste, are likely to cause harm to the environment and/or to human health. Customers living in the European Union can contribute to protecting the environment and health by returning old products to an appropriate collection point in their neighborhood in accordance with EU Directive 2012/19/UE. Collection points are provided by some distributors of the products and local authorities. Products marked with the recycling symbol on the left must not be disposed of in normal household waste.

## 8.2 Glossary

AVG:	Average depth, calculated from the beginning of the dive or from the time of reset.
CNS O <sub>2</sub> :	Central Nervous System oxygen toxicity.
Desat:	Desaturation time. The time needed for the body to completely eliminate any nitrogen taken up during diving.
Dive time:	The time spent below a depth of 0.8m/3ft.
Gas:	Refers to the main gas that is set for the ZH-L16 ADT MB algorithm.
INT.:	Surface interval. Elapsed time since your last dive ended.
Local time:	The time in the local time zone.
Max depth:	Maximum depth reached during the dive.
MB:	Microbubble. Microbubbles are tiny bubbles that can build up in a diver's body during and after a dive.
MOD:	Maximum Operating Depth. This is the depth at which the partial pressure of oxygen (ppO <sub>2</sub> ) reaches the maximum allowed level (ppO <sub>2</sub> max). Diving deeper than the MOD will expose the diver to unsafe ppO <sub>2</sub> levels.
Nitrox:	A breathing mix made of oxygen and nitrogen, with the oxygen concentration being 22% or higher. In this manual, air is considered as a particular type of nitrox.
No Fly:	Minimum amount of time a diver should wait before taking a plane.
No-stop time:	This is the time that a diver can stay at the current depth and still make a direct ascent to the surface without having to perform decompression stops.
O <sub>2</sub> :	Oxygen.
%O <sub>2</sub> :	Oxygen concentration used by the dive computer in all calculations.
ppO <sub>2</sub> :	Partial pressure of oxygen. This is the pressure of the oxygen in the breathing mix. It is a function of depth and oxygen concentration. A ppO <sub>2</sub> higher than 1.6bar is considered dangerous.
ppO <sub>2</sub> max:	The maximum allowed value for ppO <sub>2</sub> . Together with the oxygen concentration it defines the MOD.
Press:	The act of pressing and releasing one of the buttons.
Press-and-hold:	The act of pressing and holding one of the buttons for 1 second before releasing it.
SOS mode:	The result of having completed a dive without respecting all mandatory decompression obligations.
Stopwatch:	A stopwatch. To time certain steps of the dive.
UTC:	Universal Time Coordinated. Refers to time zone changes when traveling.

### 8.3 Index

Active backlight	10
All-silent mode	29, 31
Ascent rate	15
Backlight	7, 10
Battery	9, 32, 35
Buttons	7
Clock settings	29, 10
CNS O <sub>2</sub>	5, 15, 16, 16, 19, 22, 37
Date	31
Desaturation	5, 8
Desaturation reset	24, 25, 28
Dive planner	21
Diving at altitude	20
Flying after diving	19, 28, 37
Logbook	10, 11, 15, 18, 19, 20, 23, 33
LogTRAK	6, 11, 13, 25, 29, 32
Maintenance	34
Microbubbles	8, 15, 18, 19, 22, 37
MOD	12, 13, 16, 21, 37, 26
Mountain lakes	20
Nitrox	12, 26, 37
Nitrox reset	26
No-dive warning	19, 21, 24
No-fly time	37
Oxygen concentration	34, 37, 12
Oxygen partial pressure	12, 16
PC interface	32
PpO <sub>2</sub> max	16, 12, 13, 25, 37
Safety stop timer	7, 18, 27
SOS mode	10, 18, 37
Stopwatch	37
Surface interval	8, 18, 37
Technical information	34
Time of day	7, 7
Time zone	37, 30
Units	28
UTC	30, 37
Wake-up warning	10
Warning clock	10
Warnings	12, 33
Water contact	7
Water type	21, 25, 27